

REFERENCES

1 (3) Location code

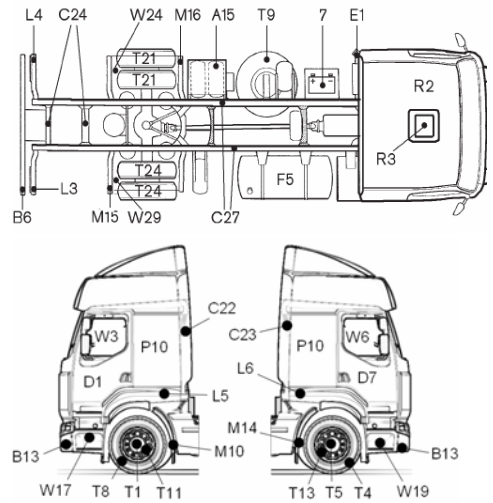
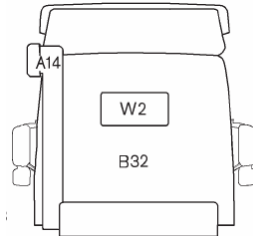
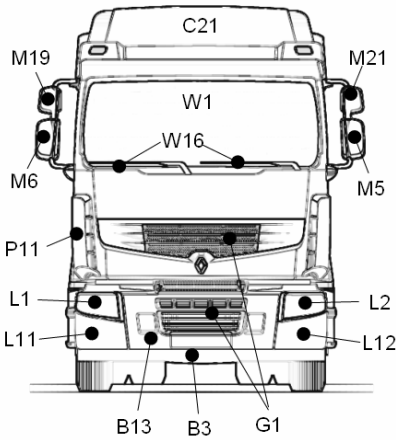

2 (4) Defect code

CODE	EN	FR	DE	ES	IT	SE	NL
13	Puncture	Percé / Crevé	Reifenpanne	Perforación	Pneumatico forato	Punktering	Lekke band
27	Dent	Bosse	Beule	Abolladura	Ammaccatura	Buckla	Deuk
28	Scratch	Rayure / Eraflore	Kratzer	Arañazo	Graffio	Repa	Kras
29	Paint Chip	Ecaille de peinture	Lackspritzer	Pintura desportillada	Vernice Scheggiata	Lackavslag	Lakpunt
53	Missing	Manquant	Fehlteile	Faltante	Mancanze	Saknas	Ontbreekt
82	Broken	Cassé	Abgebrochene Teile	Roto	Rottura di pezzo	Avbruten	Stuk

STATEMENT

(1) Vehicle model: (2) Chassis Number:

(5) Code **1** (6) Code **2** (7) Notes:

.....

.....

.....

A		(9) FROM:	➔	(10) TO:	B
(a) Transport references:	(c) <input type="checkbox"/> Factory Factory <input type="checkbox"/>	(a) Transport references:		(c) <input type="checkbox"/>	
(b) Company:	<input type="checkbox"/> Air Air <input type="checkbox"/>	(b) Company:		<input type="checkbox"/>	
(d) Name:	<input type="checkbox"/> Road Road <input type="checkbox"/>	(d) Name:		<input type="checkbox"/>	
(e) Signature & stamp:	<input type="checkbox"/> Distribution Distribution <input type="checkbox"/>	(e) Signature & stamp:		<input type="checkbox"/>	
(f) Date:	<input type="checkbox"/> Rail Rail <input type="checkbox"/>	(f) Date:		<input type="checkbox"/>	
(g) City:	<input type="checkbox"/> Body Builder Body Builder <input type="checkbox"/>	(g) City:		<input type="checkbox"/>	
	<input type="checkbox"/> Sea Sea <input type="checkbox"/>			<input type="checkbox"/>	
	<input type="checkbox"/> Retailer Retailer <input type="checkbox"/>			<input type="checkbox"/>	

IMPORTANT

**RESERVATIONS AT DELIVERY MUST APPEAR ON THE CMR [INTERNATIONAL CONSIGNEMENT NOTE]
PLEASE USE VCR [THIS DOCUMENT] AS A SUPPORT TO DETAIL NOTICED DAMAGES**